

HILBERT PAIRS OF M -BAND ORTHONORMAL WAVELET BASES

Caroline Chaux¹, Laurent Duval² and Jean-Christophe Pesquet¹

¹Institut Gaspard Monge / UMR-CNRS 8049
Université Marne-la-Vallée, Champs-sur-Marne
77454 Marne-la-Vallée, France
e-mail: {chaux,pesquet}@univ-mlv.fr

² Institut Français du Pétrole
Technology Department
92500 Rueil Malmaison, France
e-mail : laurent.duval@ifp.fr

ABSTRACT

Recently, there has been a growing interest for wavelet frames corresponding to the union of an orthonormal wavelet basis and its dual Hilbert transformed wavelet basis. However, most of the existing works specifically address the dyadic case. In this paper, we consider orthonormal M -band wavelet decompositions, since we are motivated by their advantages in terms of frequency selectivity and symmetry of the analysis functions, for $M > 2$. More precisely, we establish phase conditions for a pair of critically subsampled M -band filter banks. The conditions we obtain generalize a previous result given in the two-band case [1]. We also show that, when the primal filter bank and its wavelets have symmetry, it is inherited by their duals. Furthermore, we give a design example where the number of vanishing moments of the approximate dual wavelets is imposed numerically to be the same as for the primal ones.

1. INTRODUCTION

Critically subsampled two-channel filter banks with perfect reconstruction are proved to be efficient tools in the field of signal or higher dimensional data processing, especially for denoising, detection, or compression. Wavelets have demonstrated excellent performance in numerous applications but their successes are mitigated by some natural limitations: a lack of shift-invariance and some design restrictions.

On the one hand, a classical drawback of the real discrete wavelet transform (DWT) is its shift-variance and its poor directionality in higher dimensions. One possible solution comes from the adjunction of some redundancy in the transform. Shift-invariant wavelet transforms [2] suppress shift dependencies, at the expense of an increased computational cost and a redundancy factor depending on the decomposition level, typically $\log_2 N$ in one dimension, N being the number of samples. Less demanding solutions have been developed, by the use of complex filters for real signals (we refer to [3] for an overview and design examples), or by employing other wavelet frames. One of the most interesting and effective proposal is the *dual-tree* discrete wavelet transform, proposed by N. Kingbury [4]. In the latter and companion works, two wavelet trees are developed in parallel, with root filters being offset by one half sample to each other. The resulting analysis yields a limited redundancy of 2^d for d -dimensional signals, with a much lower shift sensitivity than the DWT and much better directionality. The design of the associated filters was recently addressed and extended by I. Selesnick [1], through an — at least approximate — Hilbert pair formulation for the "dual" wavelets. The later result was recently proved to be the "only" possible solution in [5]. Selesnick also proposed the double-

density DWT, with a redundancy factor of $(3^d - 1)/(2^d - 1)$. He finally combined both frame approaches in [6]. An extension of the *dual-tree* DWT named *phaselets* has recently been introduced by R. Gopinath in [7]. The advantages of Hilbert pairs have been earlier recognized by other authors, such as P. Abry *et al.* [8] or W. Freeman *et al.* [9]. Wavelet frames are also addressed by oversampling, as in the context of shiftable transforms [10]. More recently, several authors have proposed a projection scheme with an explicit control of the redundancy [11]. The developed framework resulted in the original 3-band complex filter bank described in [12]. Another recent approach is the "analytic" wavelet thresholding developed by S. Ohlede *et al.* [13], in the context of denoising.

On the other hand, classical 2-band wavelets also suffer from constraints in their design. In image applications, filter symmetry is often considered as important to minimize boundary artifacts and save computations, as well as finite support for dealing with realistic finite length signals. But compactly supported, real, orthogonal wavelets cannot have linear phase, except for the Haar system, whose regularity is far too limited. As a consequence, some authors have developed quickly decaying wavelets, nearly symmetric filters (such as the *symmlets*), symmetric biorthogonal filters (such as the 9/7 or 5/3 used in the JPEG 2000 standard) or "almost real" complex filters (*i.e.* with relatively few energy remaining in the imaginary component of the filtered signal, *e.g.* in [14]). Although having been very successful in many applications, the dyadic decomposition is sometimes considered relatively coarse in the highest frequency subbands. Furthermore, since the high-pass filter in the 2-band scheme heavily depends on the low-pass filter, the wavelet filters' design sometimes lacks degrees of freedom. These constraints have altogether motivated the development of more general M -band structures such as M -band wavelets [15] or M -channel Lapped Transforms.

Based on the aforementioned shortcomings and potential workouts to alleviate some of the DWT drawbacks, we propose in this work to extend the dual-tree framework to M -band wavelets. In other words, we develop a redundant decomposition on two M -band orthogonal wavelet bases, where the $M - 1$ wavelets are required to be Hilbert pairs. The organization of the paper is as follow : in Section 2, we explain how to construct the related M -band filter bank. In Section 3, we provide a design example using the resulting conditions. Some conclusions are drawn in Section 4.

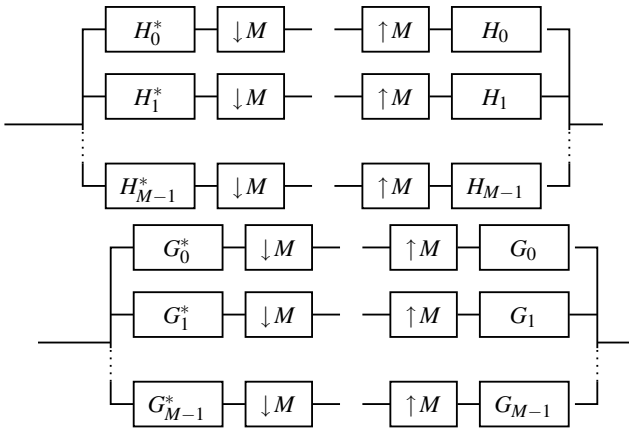

Figure 1: A pair of analysis/synthesis M -band para-unitary filter banks.

2. CONSTRUCTION OF M -BAND HILBERT PAIRS

2.1 Problem statement

Let M be an integer greater than or equal to 2. Recall that an M -band multiresolution analysis is defined by one scaling function $\psi_0 \in L^2(\mathbb{R})$ and $(M-1)$ mother wavelets $\psi_m \in L^2(\mathbb{R})$, $m \in \{1, \dots, M-1\}$ [15]. These functions are solutions of the following scaling equations:

$$\forall m \in \{0, \dots, M-1\}, \quad \frac{1}{\sqrt{M}} \psi_m \left(\frac{t}{M} \right) = \sum_{k=-\infty}^{\infty} h_m[k] \psi_0(t-k), \quad (1)$$

where the sequences $(h_m[k])_{k \in \mathbb{Z}}$ are real-valued and square summable. The Fourier transform of $(h_m[k])_{k \in \mathbb{Z}}$ is a 2π -periodic function, denoted by H_m . For the set of functions $\cup_{m=1}^{M-1} \{M^{-j/2} \psi_m(M^{-j}t - k), (j, k) \in \mathbb{Z}^2\}$ to correspond to an orthonormal basis of $L^2(\mathbb{R})$, the following para-unitarity conditions must hold:

$$\forall (m, m') \in \{0, \dots, M-1\}^2, \quad \sum_{p=0}^{M-1} H_m \left(\omega + p \frac{2\pi}{M} \right) H_{m'}^* \left(\omega + p \frac{2\pi}{M} \right) = M \delta_{m-m'}, \quad (2)$$

where $\delta_m = 1$ if $m = 0$ and 0 otherwise. In this case, cascading the M -band para-unitary analysis and synthesis filter bank, depicted in Fig. 1, allows to decompose and to reconstruct perfectly a given signal.

Our objective is to construct a “dual” M -band multiresolution analysis defined by a scaling function ψ_0^H and mother wavelets ψ_m^H , $m \in \{1, \dots, M-1\}$. More precisely, the mother wavelets will be obtained by a Hilbert transform from the “original” wavelets ψ_m , $m \in \{1, \dots, M-1\}$. In the Fourier domain, the desired property reads:

$$\forall m \in \{1, \dots, M-1\}, \quad \widehat{\psi}_m^H(\omega) = -i \operatorname{sign}(\omega) \widehat{\psi}_m(\omega), \quad (3)$$

where \widehat{a} denotes the Fourier transform of a function a and sign is the signum function. Furthermore, the functions ψ_m^H are defined by scaling equations similar to (1) involving real-valued sequences $(g_m[k])_{k \in \mathbb{Z}}$. In order to generate a dual

M -band orthonormal wavelet basis of $L^2(\mathbb{R})$, the Fourier transforms G_m of these sequences must also satisfy the para-unitarity conditions as expressed by Eq. (2).

2.2 Sufficient conditions

If we further impose that:

$$|\widehat{\psi}_0^H(\omega)| = |\widehat{\psi}_0(\omega)|, \quad (4)$$

the scaling equations combined with the Hilbert condition (3) lead to

$$\forall m \in \{0, \dots, M-1\}, \quad G_m(\omega) = e^{-i\theta_m(\omega)} H_m(\omega), \quad (5)$$

where θ_m is 2π -periodic. These functions should also be odd (for real filters) and thus only need to be determined over $[0, \pi]$. Assuming that (2) is satisfied, it is then straightforward to verify that the para-unitarity conditions for the dual filter bank hold if the following condition holds:

(P). for all $(m, m') \in \{0, \dots, M-1\}^2$ with $m < m'$,

$$\alpha_{m,m'} = \theta_{m'} - \theta_m \quad \text{is a } 2\pi/M\text{-periodic function.}$$

We are then able to state the following result whose proof is omitted here:

Proposition 1. *Assume that Conditions (5) hold. A necessary and sufficient condition for (3) to be satisfied is:*

$$\forall m \in \{1, \dots, M-1\}, \quad \alpha_{0,m} \left(\frac{\omega}{M} \right) + \beta(\omega) = \frac{\pi}{2} \operatorname{sign}(\omega) [2\pi], \quad (6)$$

where

$$\beta(\omega) = \sum_{i=1}^{\infty} \theta_0 \left(\frac{\omega}{M^i} \right). \quad (7)$$

The above two relations constitute a generalization to the M -band case of a famous result by Selesnick [1] restricted to dyadic wavelets. It is worth noting that the function β is given by the following “additive” scaling equation:

$$\beta(\omega) = \beta \left(\frac{\omega}{M} \right) + \theta_0 \left(\frac{\omega}{M} \right). \quad (8)$$

2.3 Linear phase solution

In the 2-band case (under weak assumptions), θ_0 verifying Eqs. (6) and (7) is a linear function on $[-\pi, \pi]$ [1]. In the M -band case, we will slightly restrict this constraint on a smaller interval by imposing:

$$\forall \omega \in [0, 2\pi/M[, \quad \theta_0(\omega) = \gamma\omega, \quad (9)$$

where $\gamma \in \mathbb{R}$. Using Eq. (8), after some tedious calculations, we prove the following result.

Proposition 2. *Under the three conditions (5), (P) and (9), there exists a unique solution to Eq. (6) (mod. 2π), given by*

$$\forall m \in \{1, \dots, M-1\}, \forall \omega \in]0, 2\pi/M[, \quad \alpha_{0,m}(\omega) = \frac{\pi}{2} - \frac{M}{2} \omega, \quad (10)$$

and

$$\forall p \in \left\{ 0, \dots, \left\lceil \frac{M}{2} \right\rceil - 1 \right\}, \forall \omega \in \left[p \frac{2\pi}{M}, (p+1) \frac{2\pi}{M} \right[, \quad \theta_0(\omega) = \frac{M-1}{2} \omega - p\pi. \quad (11)$$

It should be noted that unlike in the 2-band case, θ_0 may exhibit discontinuities on $]0, \pi[$ due to the $p\pi$ term. We subsequently deduce that the functions θ_m , $m \in \{1, \dots, M-1\}$, should be chosen all equal to

$$\theta_m(\omega) = \begin{cases} \frac{\pi}{2} - \frac{\omega}{2} & \text{if } \omega \in]0, 2\pi[, \\ 0 & \text{if } \omega = 0. \end{cases} \quad (12)$$

2.4 Symmetry properties

As already pointed out, one of the main advantage of the M -band case with $M > 2$ is to allow the construction of non-trivial real orthonormal bases with compact support *and* symmetric (or antisymmetric) wavelets. Assume that these properties are fulfilled for the primal filter bank. Although the Hilbert transformed wavelets are no longer compactly supported, we now show that the dual filters and wavelets still inherit these symmetry properties. Indeed, it can be proved that:

Proposition 3. *Let the conditions established in Section 2.3 be satisfied. If the low-pass impulse response $(h_0[k])_{k \in \mathbb{Z}}$ is symmetric w.r.t. $(L-1)/2$ where $L \in \mathbb{Z}$ and, for $m \in \{1, \dots, M-1\}$, $(h_m[k])_{k \in \mathbb{Z}}$ is symmetric (resp. antisymmetric) w.r.t. $(L-1)/2$, then $(g_0[k])_{k \in \mathbb{Z}}$ is symmetric w.r.t. $(L+M)/2-1$ and, for $m \in \{1, \dots, M-1\}$, $(g_m[k])_{k \in \mathbb{Z}}$ is antisymmetric (resp. symmetric) w.r.t. $L/2-1$.*

We deduce from this result that, if ψ_0 is symmetric w.r.t.

$$\tau = \frac{L-1}{2(M-1)} \quad (13)$$

and, for $m \in \{1, \dots, M-1\}$, ψ_m is symmetric (resp. antisymmetric) w.r.t. τ , then ψ_0^H is symmetric w.r.t. $\tau+1/2$ and, for $m \in \{1, \dots, M-1\}$, ψ_m^H is antisymmetric (resp. symmetric) w.r.t. τ .

3. DESIGN EXAMPLE

To illustrate the interest of the above conditions, we consider a 4-band ($M=4$) para-unitary filter bank and design its dual filter bank.

3.1 Design of the Filters

The primal filter bank is taken from [16]. It consists in four finite impulse response (FIR) filters of length 16, generating regular, orthonormal and symmetric basis functions. The corresponding filter coefficients are listed in the first four columns of Table 1.

The frequency responses of these filters can be calculated and the frequency responses of the dual filter bank can be deduced using Eqs. (5), (11) and (12). Unfortunately, the resulting filters are not FIR and we subsequently realize causal FIR approximations of the dual filters. These approximations are obtained by minimizing the L^2 norm of the error w.r.t. the desired frequency responses. As the quality of the approximations obviously depends on the filter lengths, we introduced a 2 sample delay in the original filters so as to allow more than 16 coefficients for the dual ones. Further constraints were added in the design process, namely the desired symmetry properties and vanishing moment conditions. The latter conditions are useful in order to introduce regularity conditions on the approximate dual wavelets. Recall that

a necessary and sufficient condition for the wavelets to have K vanishing moments is [15]:

$$G_0(\omega) = \left(\frac{1 - e^{-iM\omega}}{1 - e^{-i\omega}} \right)^K Q(\omega), \quad (14)$$

where $Q(\omega)$ is a polynomial function of $e^{-i\omega}$. This relation is also equivalent to the following constraints for the sequences $(g_m[k])_{k \in \mathbb{Z}}$, $m > 1$:

$$\forall m \in \{1, \dots, M-1\}, \forall k \in \{0, \dots, K-1\}, \sum_k n^k g_m[k] = 0. \quad (15)$$

As all the considered constraints are linear, we have handled them by projection techniques. The coefficients listed in the last four columns of Table 1 have been obtained in this way, by setting $K=2$, which corresponds to the same number of vanishing moments as the primal decomposition.

One of the potential problem of the proposed approach is that it does not guarantee that the designed filter bank is perfectly para-unitary. One could therefore add para-unitarity constraints in the related optimization problem. This however appeared unnecessary in the considered simulation example, as we verified that

$$\max_{m, m', \ell} \left| \sum_k g_m[k] g_{m'}[k - M\ell] - \delta_{m-m'} \delta_\ell \right| \leq 3.9 \cdot 10^{-3}. \quad (16)$$

Although the upper bound is not zero as it should be ideally, its value may be considered small enough for common signal/image analysis or denoising tasks.

3.2 Associated basis functions

Given the subband filters coefficients listed in Table 1, we constructed the functions ψ_m and ψ_m^H , for $m \in \{0, \dots, 3\}$, by an iterative numerical approach using the scaling equations (1).

Fig. 2 represents the scaling function and the wavelets associated to the primal 4-band filter bank. The scaling function and the wavelets associated to the dual 4-band filter bank are plotted in Fig. 3. We observe that the constructed dual wavelets possess regularity and satisfy the symmetry properties stated in Proposition 3. Symmetry axes are represented by dotted lines.

4. CONCLUSIONS

In this paper, we have proposed an extension of the work [1] by I. Selesnick on Hilbert transform pairs of wavelet bases to the orthogonal M -band case, by establishing phase conditions on the related filters.

We have designed filters of the dual filter bank. The resulting wavelet bases exhibit attractive symmetry and regularity properties. These encouraging design results will be adapted to forthcoming signal processing applications, especially in the field of seismic data. Taking advantages of the Hilbert pair conditions and M -band features which offer additional degrees of freedom, this new transform is promising for denoising purposes. Furthermore, the extension to 2-D or higher dimensions yields an improved directionality.

n	$h_0(n)$	$h_1(n)$	$h_2(n)$	$h_3(n)$	$g_0(n)$	$g_1(n)$	$g_2(n)$	$g_3(n)$
0	-	-	-	-	-0.0039	-0.0017	-0.0078	0.0043
1	-	-	-	-	-0.0057	0.0024	-0.0170	0.0169
2	0.0305	-0.0199	0.0199	-0.0305	0.0145	-0.0403	-0.0010	-0.0182
3	-0.0199	0.0305	-0.0305	0.0199	0.0086	-0.0136	0.0450	-0.0543
4	-0.0584	0.0381	-0.0381	0.0584	-0.0074	-0.0043	-0.0318	0.0424
5	-0.0381	0.0584	0.0584	-0.0381	0.0008	0.0025	0.1204	-0.0495
6	-0.0367	0.1688	-0.1688	0.0367	-0.0879	0.2513	-0.1305	-0.0396
7	0.1688	-0.0367	-0.0367	0.1688	-0.0548	0.3678	-0.3003	0.3032
8	0.4095	-0.5442	0.5442	-0.4095	0.0923	-0.2055	0.6121	-0.4882
9	0.5442	-0.4095	-0.4095	0.5442	0.2542	-0.7175	0	0.5661
10					0.4910			
11					0.5908			

Table 1: Coefficients of the synthesis filter banks for $M = 4$; half the coefficients are provided: h_0, h_2 (resp. h_1, h_3) are symmetric (resp. antisymmetric) of length 16; g_0 is symmetric of length 23, g_1, g_3 are symmetric of length 19 and g_2 is antisymmetric of length 19.

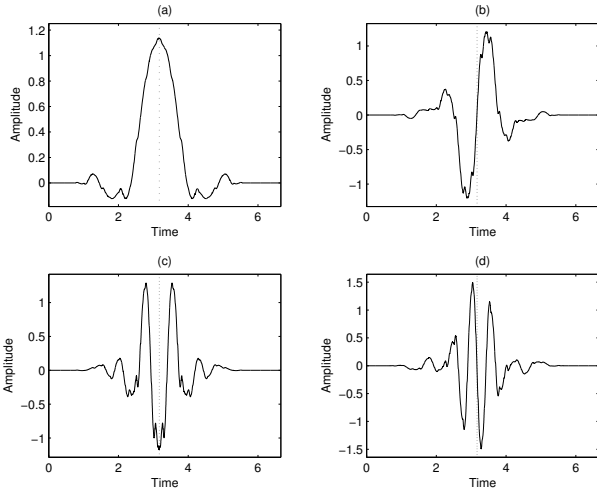

Figure 2: (a) Scaling function ψ_0 and (b) wavelet ψ_1 , (c) wavelet ψ_2 , (d) wavelet ψ_3 .

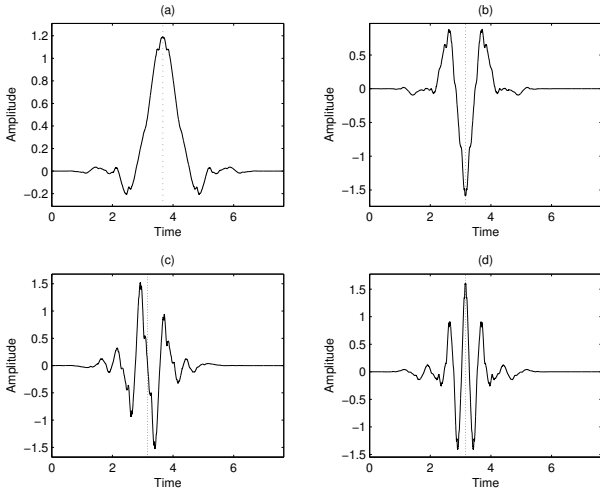

Figure 3: (a) Scaling function ψ_0^H and (b) wavelet ψ_1^H , (c) wavelet ψ_2^H , (d) wavelet ψ_3^H .

REFERENCES

- [1] I. W. Selesnick. Hilbert transform pairs of wavelet bases. *Signal Processing Letters*, 8(6):170–173, Jun. 2001.
- [2] J.-C. Pesquet, H. Krim, and H. Carfantan. Time invariant orthonormal representations. *IEEE Trans. on Signal Proc.*, 44(8):1964–1970, 1996.
- [3] X-P. Zhang, M. Desai, and Y-N. Peng. Orthogonal complex filter banks and wavelets: some properties and design. *IEEE Trans. on Signal Proc.*, 47(4), Apr. 1999.
- [4] N. G. Kingsbury. The dual-tree complex wavelet transform: a new technique for shift invariance and directional filters. In *Proc. 8th IEEE Digital Signal Processing Workshop*, 1998.
- [5] H. Özkaramanli and R. Yu. On the phase condition and its solution for Hilbert transform pairs of wavelets bases. In *Proc. Int. Conf. on Acoust., Speech and Sig. Proc.*, pages 417–420, 2003.
- [6] I. W. Selesnick. The double-density dual-tree discrete wavelet transform. *IEEE Trans. on Signal Proc.*, 2001.
- [7] R. A. Gopinath. The phaselet transform — an integral redundancy nearly shift-invariant wavelet transform. *IEEE Trans. on Signal Proc.*, Jul. 2003.
- [8] P. Abry and P. Flandrin. Multiresolution transient detection. In *Proc. Int. Symp. on Time-Freq. and Time-Scale Analysis*, pages 225–228, 1994.
- [9] W. T. Freeman and E. H. Adelson. The design and use of steerable filters. *IEEE Trans. on Pattern Anal. and Match. Int.*, 13(9):891–906, Sept. 1991.
- [10] E. P. Simoncelli, W. T. Freeman, E. H. Adelson, and D. J. Heeger. Shiftable multi-scale transforms. *IEEE Trans. on Inform. Theory*, 38(2):587–607, March 1992. Special Issue on Wavelets.
- [11] F. Fernandes, I. Selesnick, R. van Spaendonck, and C. Burrus. Complex wavelet transforms with allpass filters. *Signal Processing*, 83(8):1689–1706, 2003.
- [12] R. van Spaendonck, T. Blu, R. Baraniuk, and M. Vetterli. Orthogonal Hilbert transform filter banks and wavelets. In *Proc. Int. Conf. on Acoust., Speech and Sig. Proc.*, pages 505–508, 2003.
- [13] S. C. Olhede and A. T. Walden. Analytic wavelet thresholding. Tr-03-01, Imperial College, 2003.
- [14] B. Belzer, J.-M. Lina, and J. Villasenor. Complex, linear-phase filters for efficient image coding. In *IEEE Trans. on Signal Proc.*, Oct., 1995 43. 2425–2427.
- [15] P. Steffen, P. N. Heller, R. A. Gopinath, and C. S. Burrus. Theory of regular M -band wavelet bases. *IEEE Trans. on Signal Proc.*, 41(12), Dec. 1993.
- [16] O. Alkin and H. Caglar. Design of efficient M -band coders with linear-phase and perfect-reconstruction properties. *IEEE Trans. on Signal Proc.*, 43(9):1579–1590, 1995.